

經貿一 路 Jingmao 2nd Rd.

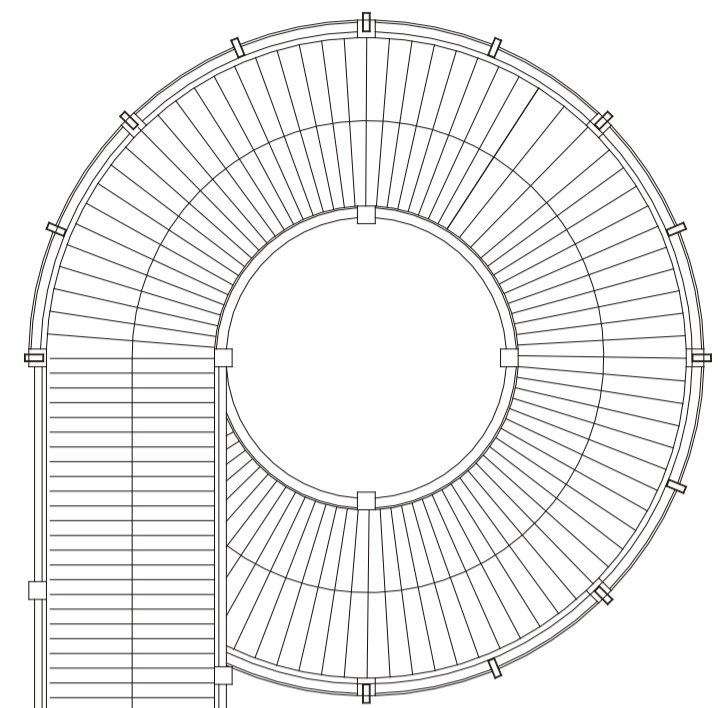
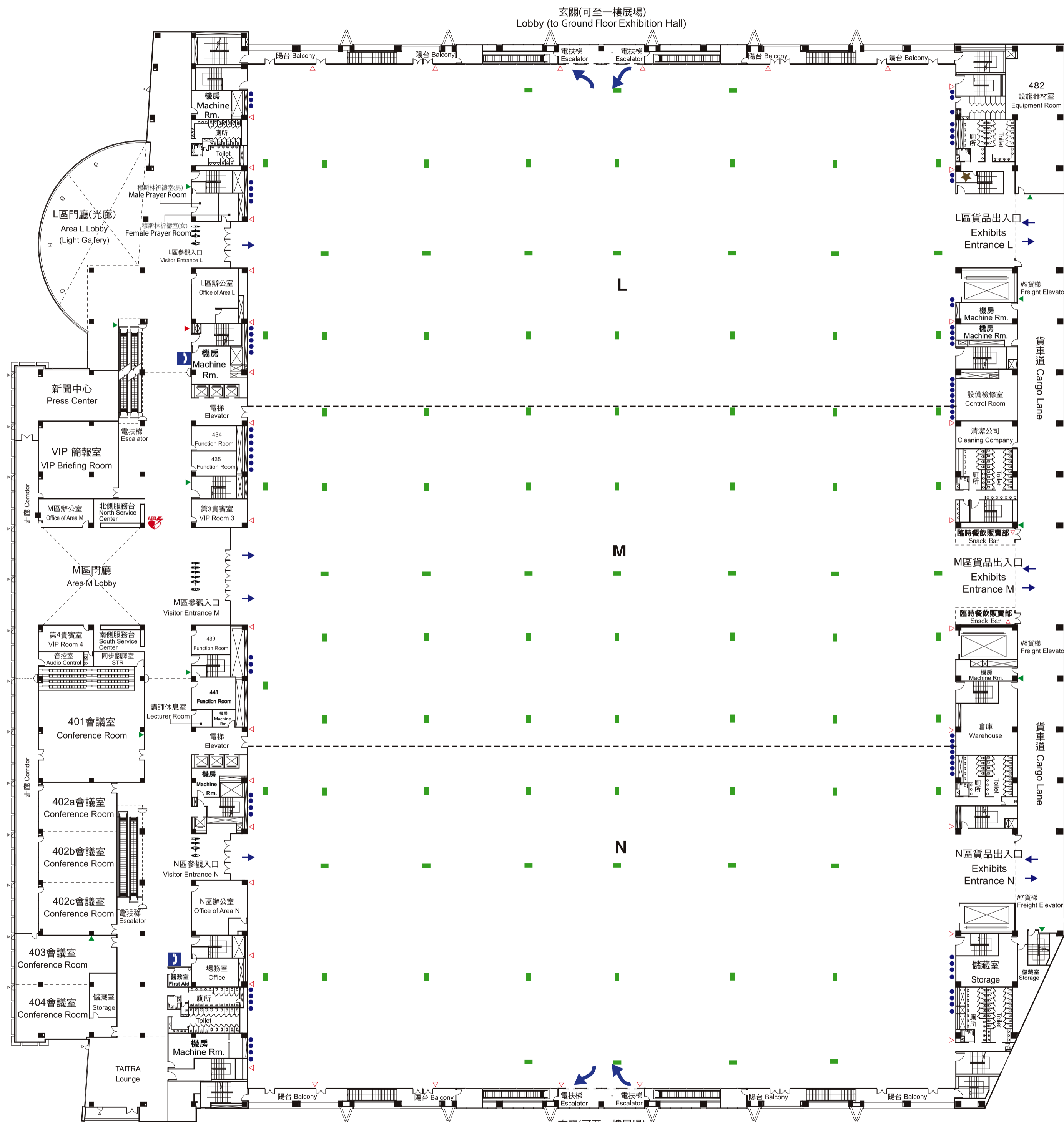

- 樓地板載重 Floor Load Capacity: 2,000kg/m²
- 展場高度 Ceiling Height: 14m~27m
- 貨品出入口尺寸 Exhibits Entrance (WxH):
L區 Area L: 11.0m x 4.0m
M區 Area M: 11.9m x 8.5m
N區 Area N: 10.1m x 4.0m
- - - 區域分界線(分區隔牆設置位置) Dotted Line (indicates different areas)

- ▶ 消防栓(含火警綜合盤) Hydrant
 - ▶ 火警綜合盤 Fire Alarm Panel
 - ▶ 滅火器 Fire Extinguisher
 - 電箱 Electric Equipment
 - 緊急出口(避難方向指示燈) Emergency Exit
- 註:
1. 火警盤、滅火器、消防栓、電箱、避難方向指示燈等皆不得封閉。
Fire alarm panel, fire extinguisher, hydrant, Electric Equipment, and all signs of the hall should not be covered.
 2. 實際位置依現場為準。
Location of devices and facilities should be confirmed on site.
- ★ 水泥漆洗滌間 Painting equipment washing room
 - ☎ 公用電話 Pay Phone
 - 🚑 自動體外心臟電擊去顫器(AED) Automated External Defibrillator

1. 本圖為標準攤位圖，僅供參考。
This is a standard floor plan for reference only and organizer may vary in dimension and composition.

2. 主辦單位所自行規劃之攤位圖，請先送外貿協會核定。
Organizer must submit planned floor map to TAITRA for prior consent.

經貿一 路 Jingmao 1st Rd.

南港展覽館站(文湖線/板南線) MRT Taipei Nangang Exhibition Center Station (Wenhu Line/Bannan Line)

南港路一段 Nangang Rd., Sec.1

台北南港展覽館1館
Taipei Nangang Exhibition Center, Hall 1
雲端展場平面圖
Sky Dome Exhibition Hall Plan(4F)

2019.9.10